

VORTEX 230 **MOJO**

Instruction Manual

International edition

Rev 1.0 - Oct 2017



IMMERSION RC
REAL VIRTUALITY

Thank You!

The team that designed the Vortex 230 Mojo would like to thank you for purchasing this product.

Many hours of development and testing went into the Vortex 230 Mojo, and we're confident this is reflected in your experience with this exciting new mini-quad, as this Vortex combines all of the greatest features of previous generations.

The Vortex 230 Mojo was designed as an racer/freestyle crossover, equipped to excel both at the race track as well as at your favorite freestyle spot. The included pro-tunes will get you up and running quickly as the mini-quad has been tuned properly right out of the box.

We would love to hear your feedback on the product, whether good or bad, at feedback@immersionrc.com.



WARNING

Congratulations on your purchase of one of the world's finest ARF pure-bred freestyle/racing mini-quads. A product designed by FPV pilots, for FPV pilots.

Do not expect it to fly like a DJI Phantom™. It does not have a return-to-home feature, no GPS, and it does not have stabilization features that will allow your little brother to fly it.

Take it easy if you are new to the world of FPV racing, find an empty field for your first flight and get comfortable with flying the quad first before you hit that downtown bando.

Acro mode is something that should be learned as soon as possible, flying any other mode is a bit like driving a Lamborghini around a parking-lot in reverse... not exactly what you bought the Lambo for.

Please carefully read the recommendations in this instruction manual, as far as equipment/battery selection, and how to run the Vortex 230 Mojo setup Wizard.



REMOVE PROPS

Mini-quad props can do serious damage when coming in contact with human skin, risk of deep cuts and lacerations should be avoided at all cost.

So when you are working on a quad with the battery connected, it is highly recommended to **REMOVE ALL PROPS**, unless you are just about to fly. Keep in mind that when setting up mini-quads, there is always a remote chance that a configuration change can spin up motors unexpectedly.

ImmersionRC accepts no responsibility, or liability, for any injury, or damage, to persons or property, caused by the use of the Vortex.



INSTALL ANTENNA

The Video Transmitter included in the Vortex may be damaged permanently if run without the supplied SpiroNET Antenna. Please take care to install this antenna before every flight, and when powering up the Vortex for even a short time period.

ImmersionRC accepts no responsibility for damage caused to the Vortex by operating without a suitable Tx antenna installed.

Getting Started for Newcomers to Racing Drones

This manual focuses on preparing your Vortex 230 Mojo for first flight, and how to maintain it in the future. One step that is highly recommended for newcomers to the world of racing drones is to take the first flight within the safety of a simulator.

Lugus Studios 'Liftoff' simulator contains a full realistic 3D simulation of the Vortex 230 Mojo, and is an ideal way to get the hang of flying a mini-quad without breaking props. Hovering, turning, carving around flags, racing through gates, all can be practiced before charging your first battery.

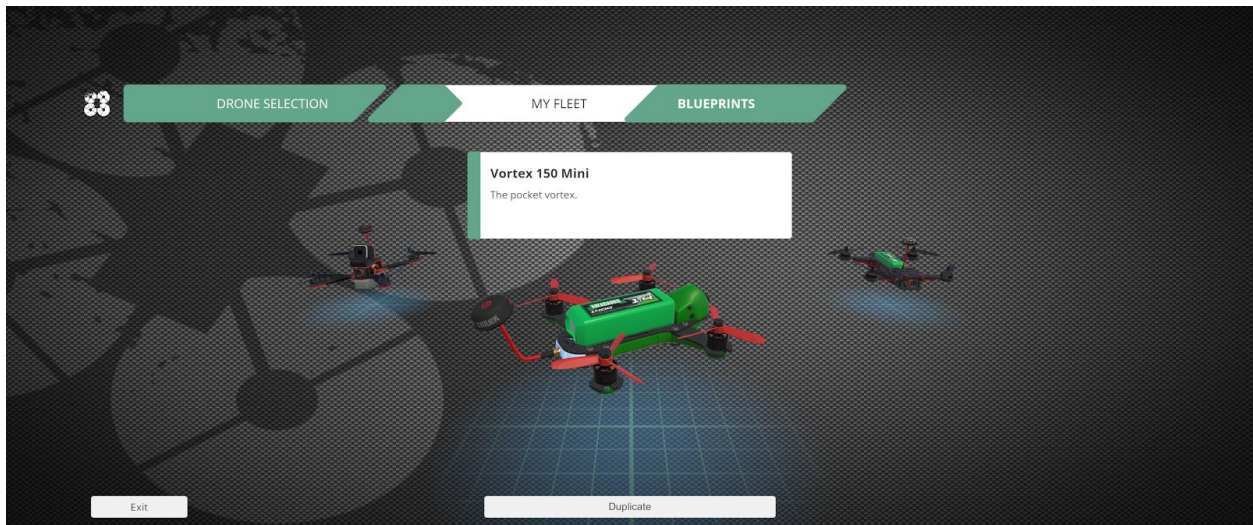

Liftoff is distributed on the Steam platform, and may be downloaded from here:

<http://store.steampowered.com/app/410340/>

Getting Started, ARF Version

The separate [Quick Start Guide](#) should be used when setting up your Vortex 230 Mojo for the first time. It includes sections on choosing an appropriate battery, and R/C receiver, and also the operation of the setup wizard.



The Anatomy of a Vortex 230 Mojo

Connectors and Switches

- 1) **USB connector**, pictured on the left, is used to configure the flight controller and upgrade the Vortex firmware. Note that when used with most USB hosts, a separate battery connection is not required when connecting to the USB connector.



Please be careful not to put too much strain on this connector. It is a lightweight surface-mount part, and if the quad is dragged around by the USB cord it may not survive.

- 2) **Reset button**, pictured right below the ImmersionRC logo on the side-plate sticker, is used to change Video Tx band, to restart the wizard and also to put a Spektrum receiver in bind mode. Press and release after 1st beep to change video band, release after 2nd beep to restart the wizard, release after 3rd beep to put a (non-autobind) spektrum rx in bind mode, finally release after 4th beep to cancel operation.

Note: To bind a Spektrum Rx using the reset button, the Vortex must be placed in SPEKTRUM 1024/2048 mode, and not AUTO mode, using the Vortex Chrome App on a PC or Mac.



WARNING: Be careful how much pressure is placed on this small button. It is a surface-mount part which may easily be damaged with a heavy-hand. Use an appropriate tool to access the recessed button (a bent paper-clip works fine), and do not push harder after the first 'click' is felt.

- 3) **Synergy FC/OSD button**, used to enter firmware update mode in the case of a 'bricked' OSD, it is positioned beneath the hole located right above the top of the anti-slip pad. Note that we don't expect this button to ever be needed, but this is where it is located just in case...

See the [Firmware Upgrades](#) chapter for more details.

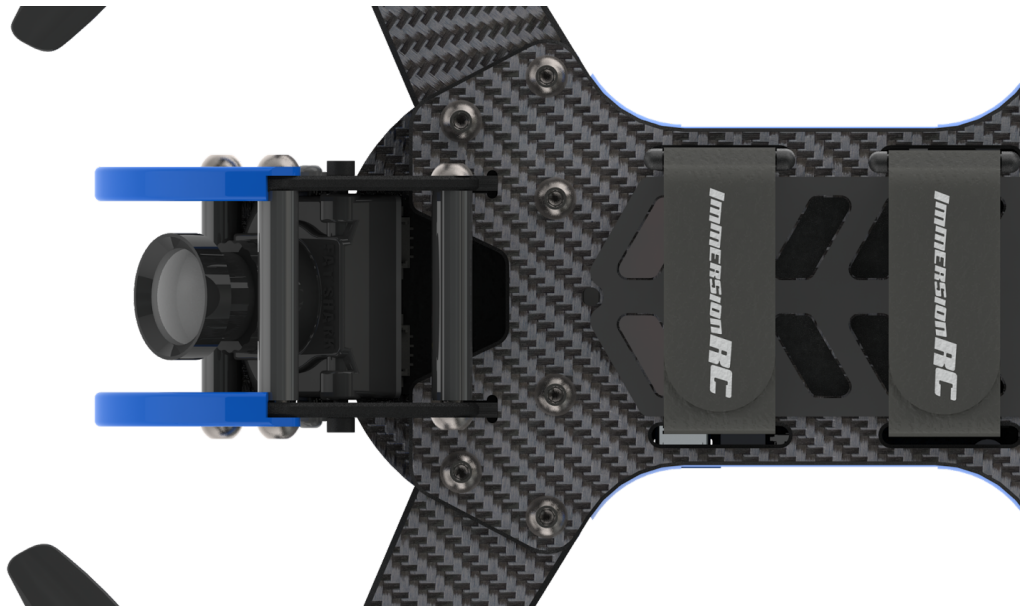

4) Receiver Connector (All Protocols, CPM, SBus, DSMX™, etc.)

The Vortex 230 Mojo has a single connector for all supported receivers. 5V and 3.3V power supplies are available, to support most of the commonly used receivers on the market today. In most cases, one of the supplied cables will suffice, but if a cable must be built, the pinout is (from left to right) Signal, GND, +3.3V and +5V.

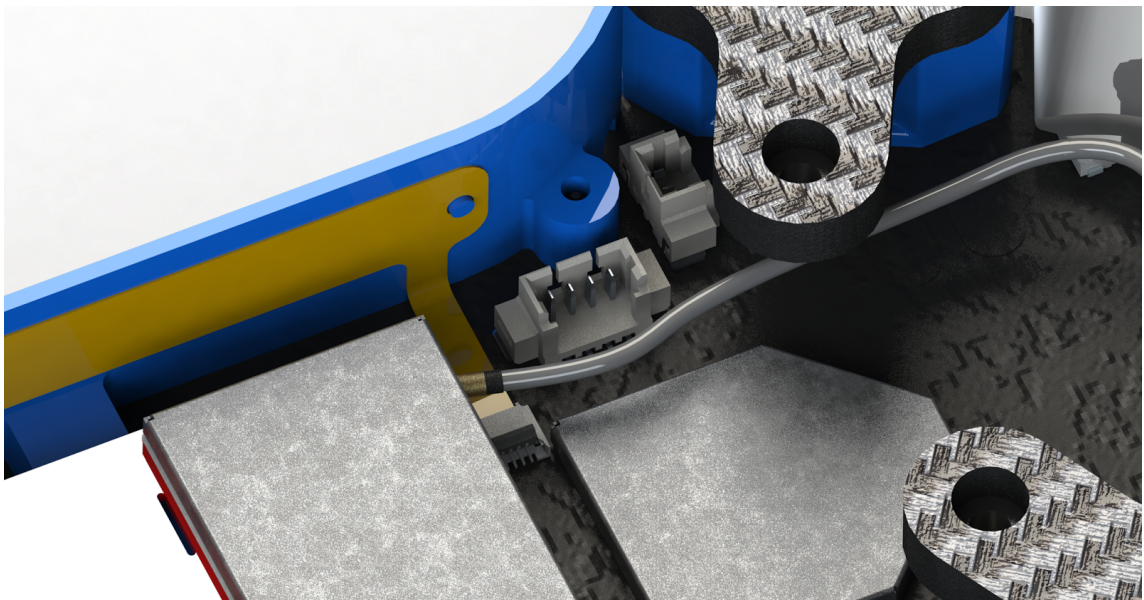

Note that a piece of double-sided tape may be used to secure the receiver on top of the metal can beside the connector.

Receiver antennas may be routed through any of the four available slots. Two at the back of the quad in the LED diffuser, and two in the side-plates. Be sure to use some extra shrinkwrap over the fragile antennas so they're better able to handle the abuse of rough landings and handling the quad.

The best solution is to route them through the holes in the side-plates in front of the rear arms but certain receivers may not have sufficiently long antenna wires, so routing them out the back is the only option in that case.

Connector Part Numbers and Sources

If any of the connectors on the Vortex 230 Mojo are damaged, or if 3rd party components are to be integrated into the system, the following list of connectors and pre-crimped wires should be useful. Obviously we also have all the cables available in a set as a spare part with part number V23CAB.

| Cable | Description | Manufacturer's PN | Digikey PN |
|--|-----------------|-------------------|------------|
| FUN/GPS Signal Connector | Picoblade 5 pin | 0510210500 | WM1723-ND |
| Camera Signal Connector | Picoblade 3 pin | 0510210300 | WM1721-ND |
| Picoblade Signal Wires (all Picoblade connectors) | Picoblade | 0006660013 | WM2320-ND |

Arm Assembly

When changing an arm, a soldering iron is required, to remove the ESC + and - battery cables, along with the signal cable.

Note: The choice of soldered connections here, instead of the much more convenient connector option may not seem ideal, but this is the best way to transmit the 30+ Amps of battery juice to the ESCs and motors without losses.

Camera Mounting

Flight Camera

The Vortex 230 Mojo is equipped with a state-of-the-art FatShark CCD camera featuring a Sony CCD and Sony chipset which puts it a step up over other popular FPV cameras.



Note that the camera tilt is adjustable. Loosen the two upper-screws and tilt the camera to the desired angle, before re-tightening them.

OSD Camera Control: The Vortex 230 Mojo is able to control the camera settings directly from the Vortex OSD, so no need for external cables with switches etc. to set it up.

Lost Model Alarm

The Lost Model Alarm on the Vortex 230 Mojo sounds when the quad is disarmed after landing, or if a receiver failsafe occurs, this alarm can also be assigned to a switch from within the Betaflight Chrome app if desired.

The alarm is designed to be as simple as possible, without controls which could allow it to be accidentally disabled, resulting in a lost quad, hence we suggest leaving it at the default setting.

The Touch'n'Race (TNR) Tag

The Touch'n'Race tag is located behind the plastic side-plate of the right-side of the quad (looking from the back).

A TNR Wand or an NFC enabled Android phone with the NFC app may be used to not only query the video transmission frequency before powering-up the quad, but also to set it to any of the supported channels before powering up.

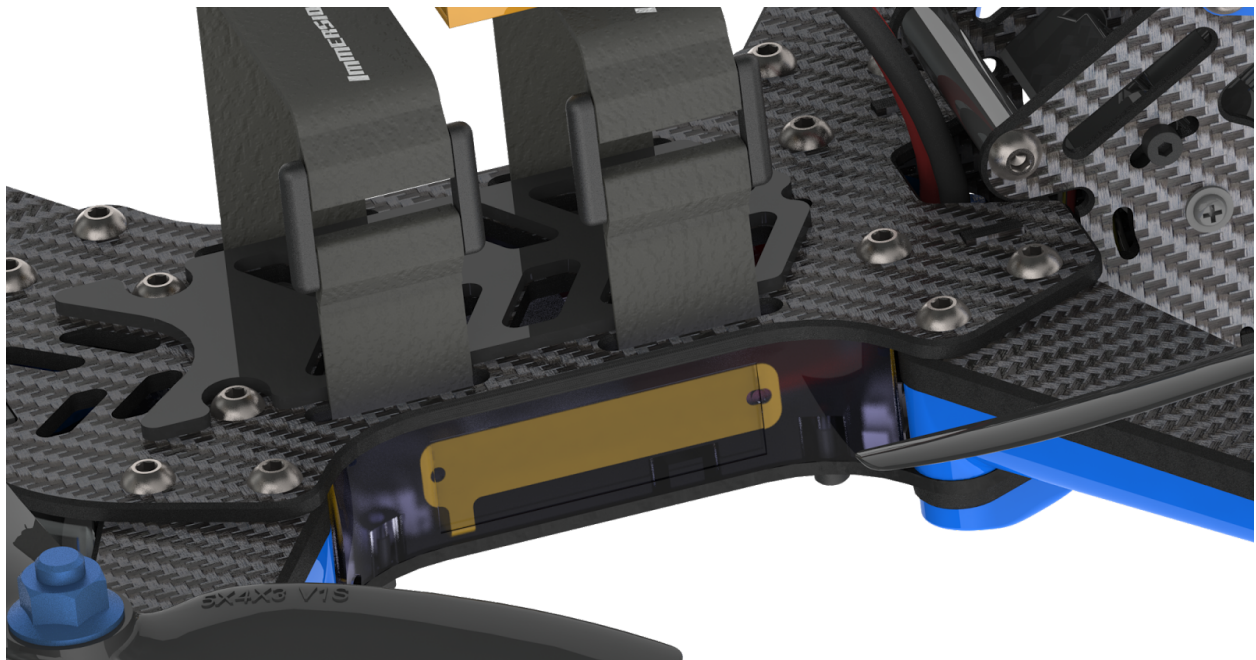

The On Screen Display (OSD)

The Welcome Screen

Each time the Vortex is powered up, and before sticks are moved, the following welcome screen is displayed.

This shows various pieces of status information, including the Flight Controller version number, and Flight Controller API version which is fairly important for OSD compatibility.



Moving the pitch/roll stick (right stick for mode 2'ers) will dismiss the menu.

The Main Menu

For Mode 2'ers, holding the throttle stick down and to the left will enter the main menu. Note that this stick position needs to be held for a few seconds before the menu appears.

Note that some menus are multi-page, take a look in the top-right corner of the display to see how many pages in the current menu, and which is selected.



To navigate the menu, use the pitch/roll stick.

The OSD Setup Menu

Various OSD setup parameters are available in this menu.

The **Landscape**, defines the elements that are shown on the main screen in flight, including an EzOSD-type landscape (the default), a clutter-free landscape for hardcore racers, and a gaming mode which is currently in Beta form (documented later in this manual).

The **Pseudo** lets you name your quad. This is useful when several Vortexes are being used in a race, and simplifies Video Tx channel assignments.

The **Pack Capacity** should be set to the capacity of your flight battery. The OSD will track battery consumption, and will warn, with screen-center alarms, if it gets critical.

NOTE: It is highly recommended to set this to match the flight pack that you are using to allow the OSD to warn you when the battery is reaching critical levels.

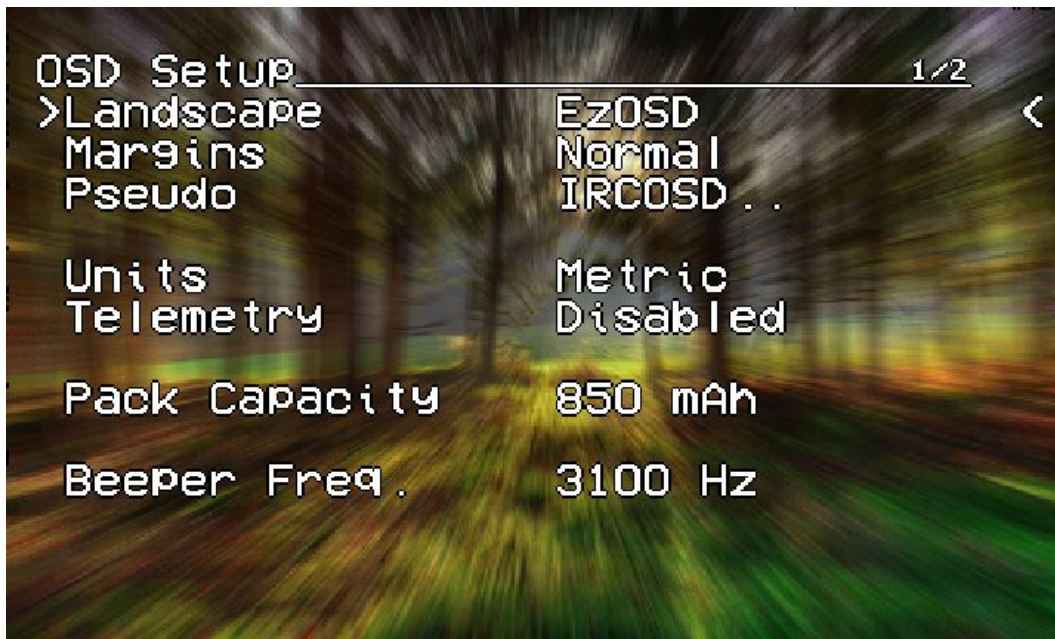

Alarms may be enabled and disabled in the **Alarms Setup** menu.

It is highly recommended to start flying with all alarms enabled, and disable them if required after getting used to the quad.

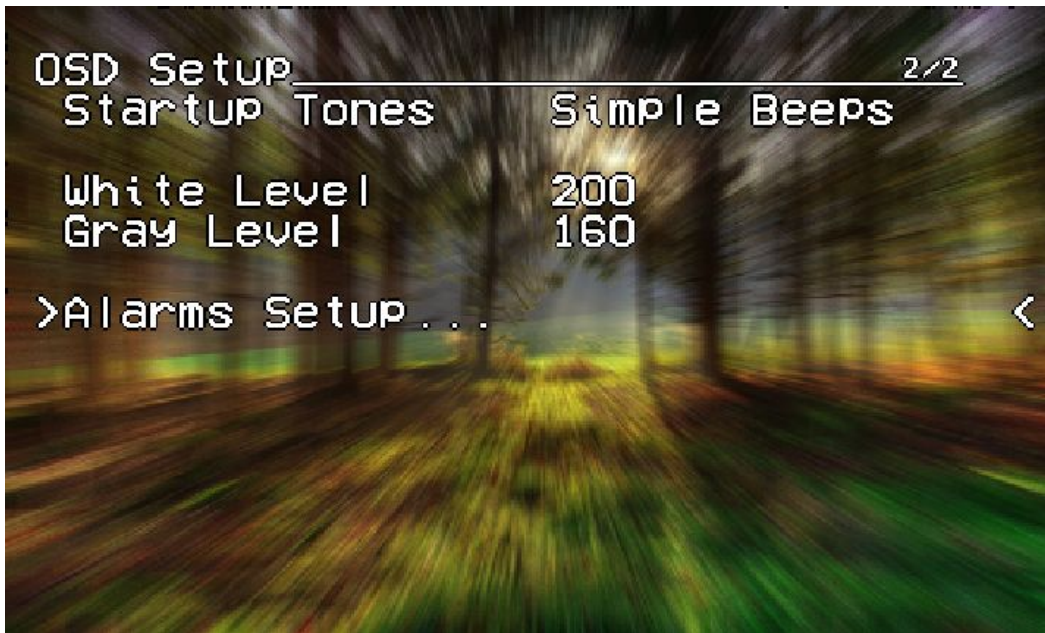

The LED Setup Menu

The RGB LEDs on the rear of the Vortex are fully programmable, with colors, and various patterns.

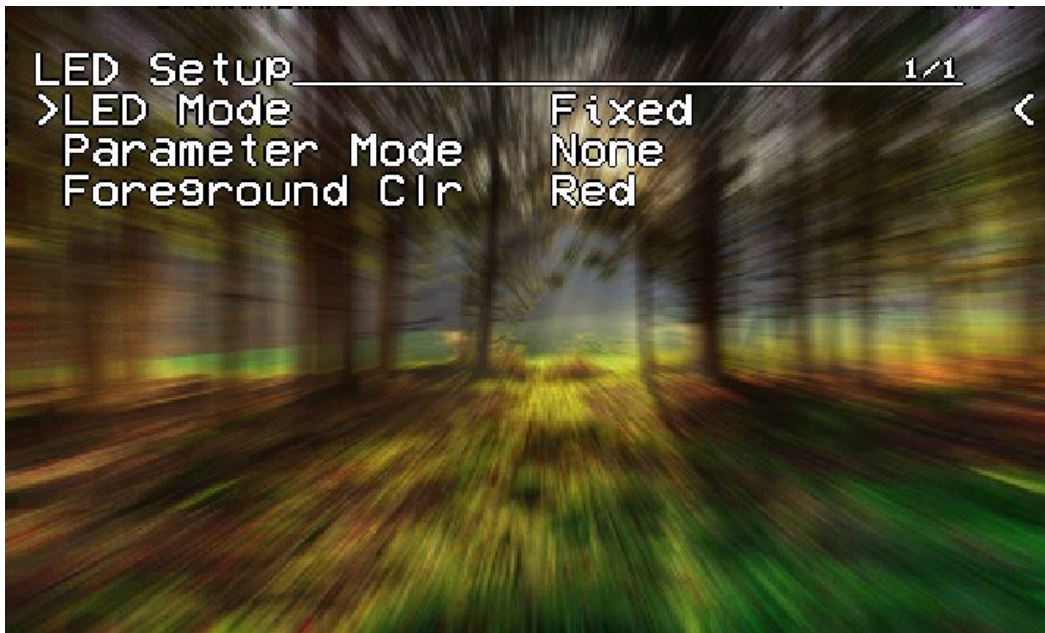

For Parameter Mode = **Intensity**, the intensity of the LEDs will reflect the current throttle position.

For Parameter Mode = **Frequency** the blink rate of the LEDs will reflect the current throttle position.

For Parameter Mode = **Gradient**, the LEDs will shift from the foreground color, to the background color, based upon the current throttle position.

Other modes will be supported in future firmware updates.

The Flight Controller Menus

In-field tweaking of flight-controller menus is possible without a laptop and USB cable. All of the critical parameters, PIDs, Expos, Loop time, etc. are available.

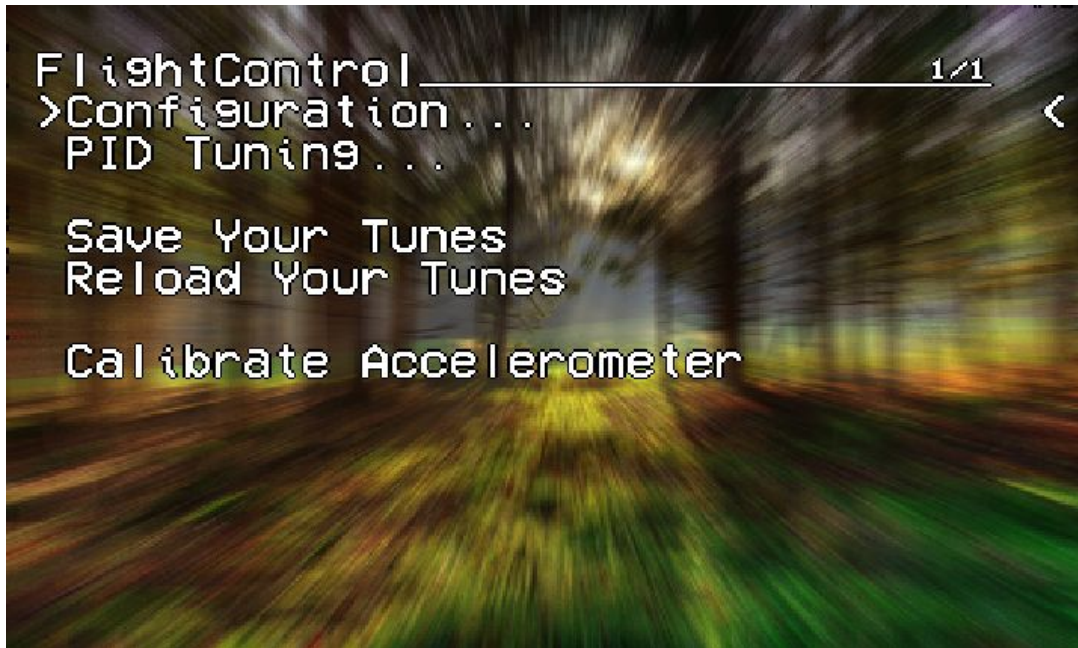

General configuration settings should not need changing, except to enable Air Mode (which is highly recommended).

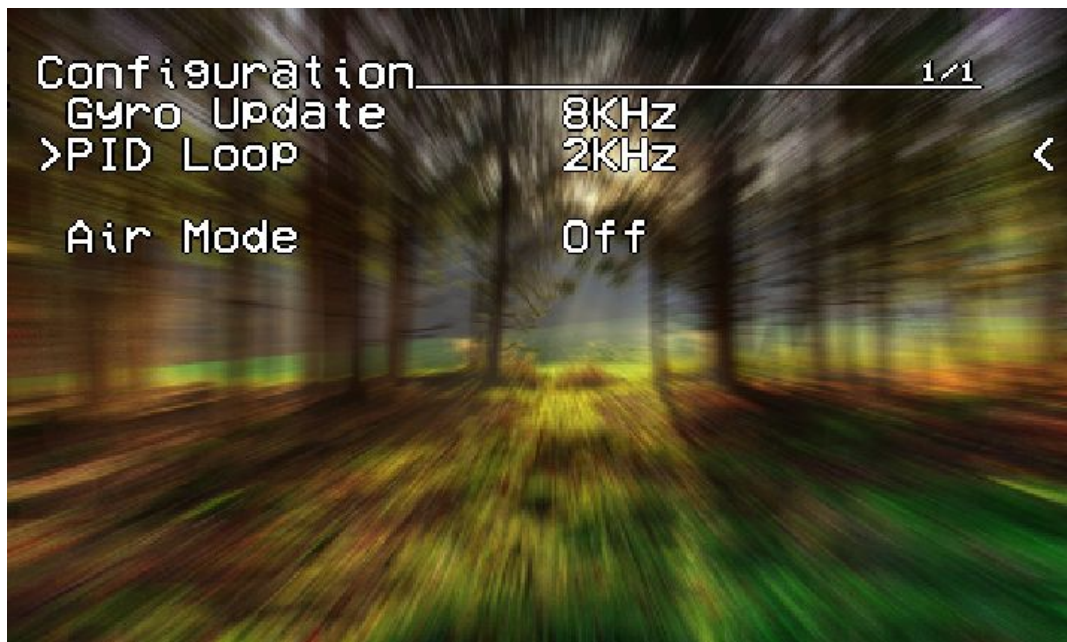

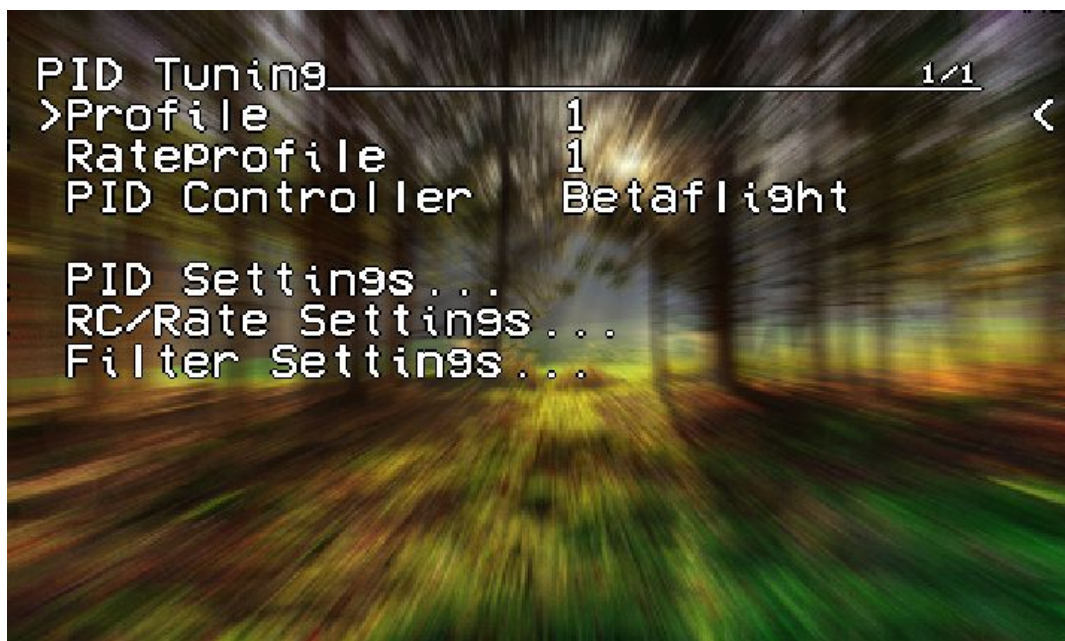

Note that the PID Settings menu is a two page menu, keep moving the caret down to access the second page.



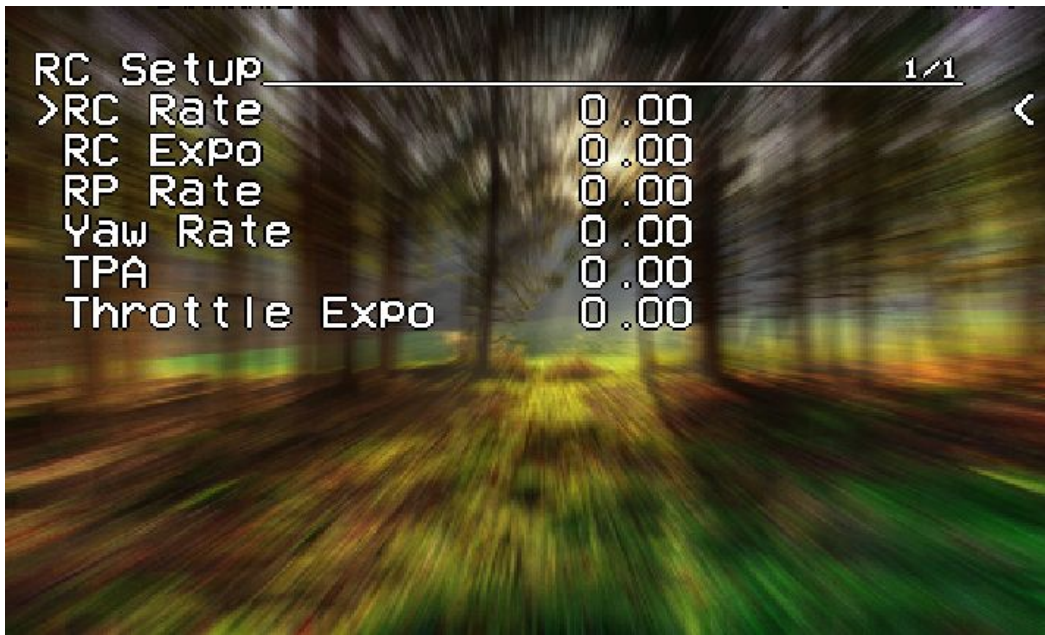

Note that all of the Flight Controller parameters can be preset by loading one of the installed [Pro-Tunes](#).

The Video Tx Menu

The Video Tx menu shows, graphically, the 5.8GHz frequency band, from low (left) through high (right) frequency.

5 bands are supported, covering the standard ImmersionRC/FatShark frequency bands, plus all of the 'Boscam', Team Black Sheep bands, and also the new ImmersionRC 'RaceBand'.

Note the need for RaceBand in this hobby is immediately obvious after looking at this graph!

NOTE: Channel 8 of the IRC/FS set cannot be received by 7 channel ImmersionRC or FatShark receivers. Unlocked Uno/Duo5800 receivers can receive it, as can the new FatShark 4-band RaceBand Dominator module.

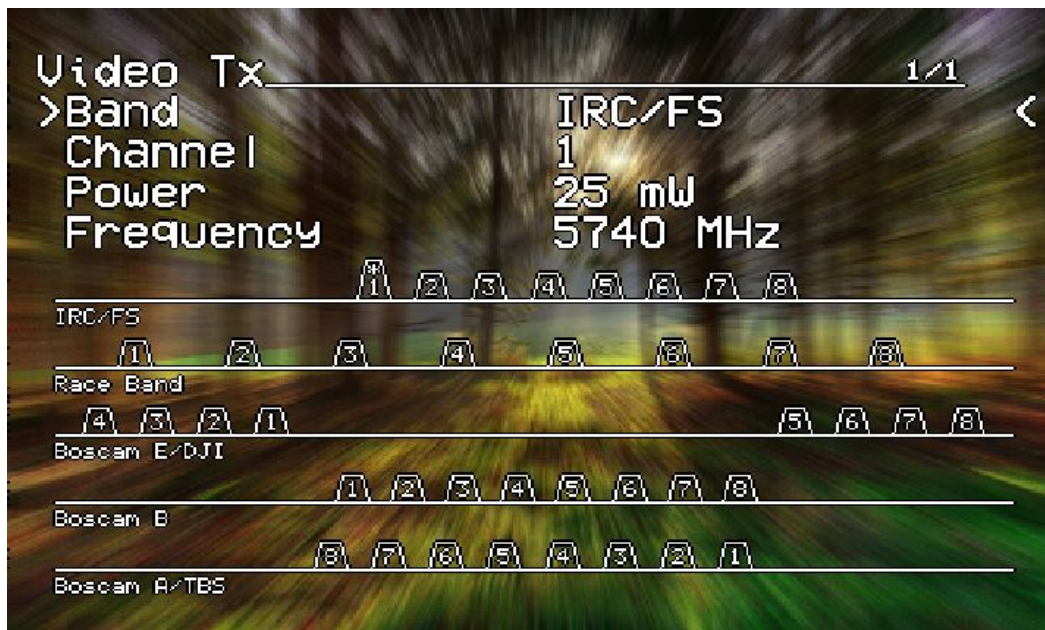

WARNING: Please pay attention to the legality of the channels that you are using in your area.

While the authorities have been relatively tolerant of emitted power on 5.8GHz, out of band transmission is a more serious issue.

In the USA, with a Ham license (required to emit more than about 1mW), operation within the 5650MHz to 5925MHz band is allowed. All 8 RaceBand channels fall within this band, but the outer channels of the Boscam E band are outside the band.

Within Europe, the Ham band is 5650MHz to 5850MHz, which allows the first 6 RaceBand channels.

NOTE #1: There are several SKUs for the Vortex 230 Mojo to allow sales in most countries. Each SKU may limit power and/or available channels.

NOTE #2: The Vortex 230 Mojo is always in 'Dynamic Power Control' mode. This limits output power to a maximum of 25mW before takeoff, and after landing (disarming). Advantages are multiple, including much lower battery consumption while waiting on the starting grid of a race and reduced temperatures.

The Camera Settings

The Camera Settings menu allows the camera settings to be modified using the camera's built-in OSD.

Ideal for tweaking settings to optimize the camera for challenging lighting conditions.



A confirmation prompt appears before entering the camera's OSD menu. When selecting YES, the OSD controls will change slightly from those used in the Vortex OSD.

For Mode 2 users, the right-stick becomes the OSD setup joystick (up/down/left/right), and the Vortex OSD 'Enter Menu' control (left stick back and left) becomes the 'select' function.

A long 'Enter Menu' control (1 second or more) returns control to the Vortex OSD.

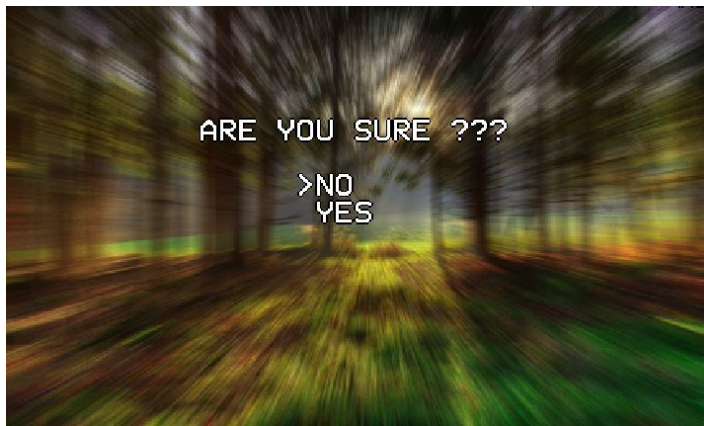

If for any reason the camera OSD control doesn't function, even if the camera has been changed for a different model, please follow the guide located in the following blog post:

[Vortex OSD Control of Camera OSDs](#)

Video Transmitter

The Vortex 230 Mojo flight controller/OSD board contains an embedded 'Tramp' 5.8GHz Video Transmitter.

The frequency, and power level of this transmitter may be programmed using several techniques (several of which are unique to this product), including:

- 1) **OSD Menu** selection (while powered up)
- 2) **TNR Wand** (even when powered down)
- 3) **PitStick** set after power-up using the R/C remote.
- 4) **DSMX** control from a supported Spektrum R/C Transmitter

OSD Menu

The OSD Menu is the 'traditional' Vortex method of configuring the video transmitter. The quad is powered up, transmits on it's last configured channel, and by entering the OSD menu, the channel may be changed.

TNR Wand

The TNR Wand allows the video transmitter to be configured before powering up the quad. This enables the wonderful feature of arriving at a park or race, asking your flying buddies what channels they are using, and picking a clear channel before powering up so as not to stomp on their channel and cause them to crash out.

The TNR feature also supports the Race Director's wand 'Race Lock' and pit mode, where quads may be integrated into race events in the same way as the Tramp HV.

NOTE: The TNR Wand feature of the 230 requires a wand either from the second production batch (v1.1), or a modified wand from the first batch (v1.0).

PitStick Mode

The new PitStick mode is enabled using the Video Tx menu, selecting the required band (typically RaceBand), and then selecting 'PitStick' as the channel number.



When in this mode, the quad will not transmit at all when powered up, but will instead play a tune occasionally after power-up to remind the pilot that PitStick is active.

For Mode 2 users, use the right stick to select the channel number, as shown below (channel 1 is straight up, each 45 degree step around the clock is another channel number).

No wand required, No OSD settings each time you arrive at the field, just power up, and set the channel using the R/C Controller.

DSMX Mode

For the DSMX mode, several of the more recent Spektrum™ radios (see table below) can set the video transmitter channel using the LCD directly on the radio.

An example of the settings from the DX9 are shown below.

Set the channel, band, and power level from the LCD, and select 'Send' to send the settings to the Vortex.



Note: To use DSMX to set the Tx settings, but not transmit immediately at power-up, select the PitStick channel following the procedure above.

The following Spektrum™ radios are either compatible out of the box (DX6e) or may be upgraded to support the vTx control menu. To create an account on the Spektrum site, and register your radio, visit the following site:

<https://www.spektrumrc.com/MyAccount/Register.aspx>

| Compatible Radios |
|-------------------|
| DX6e |
| DX6 G2, G3 |
| DX7 G2 |
| DX8 G2 |
| DX9, DX9 Black |
| DX10t |
| DX18t |
| DX18 |
| DX18 G2 |

Flight Controller

R/C Transmitter Control Modes

Mode 1 - Common in Europe

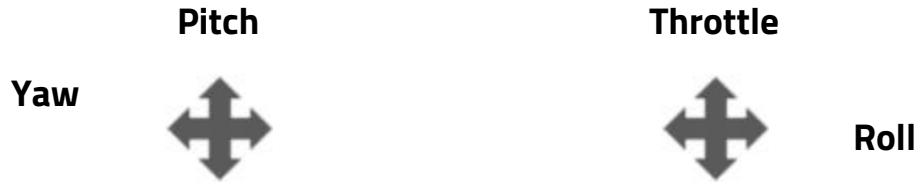

Mode 2 - Common in the USA



Mode 3



Mode 4



Flight Modes

Three flight modes are configured by the Vortex Wizard, and are mapped by default to channel 5 of the R/C Tx.

These modes are as follows:

| | |
|--------------|--|
| Acro | <p>This mode is the preferred mode for the more advanced mini-quad pilot. In many ways it is the simplest mode, but also the hardest mode to learn.</p> <p>In Acro mode, the accelerometer part of the IMU is not used, only the Gyro. Because of this, the quad will not self-level, explaining the steep learning curve for this mode.</p> <p>To learn this mode, it is recommended to start flying the quad FPV, in Angle mode, get some altitude, and switch into Acro mode.</p> <p>Landings in Acro mode can be a bit challenging for the beginner, so switching to Angle mode before landing is a reasonable way to deal with this.</p> <p>Acro mode is the ideal mode to have fun with flips and rolls.</p> |
| Angle | <p>Angle mode is the easiest to learn. When the sticks are centered, the flight controller is always working to level the quad.</p> <p>The deviation of the Roll/Pitch controls from neutral defines the angle of the quad in flight.</p> <p>Not a great mode for racing, but definitely the mode to use for the maiden flight.</p> |
| Horiz | <p>Horiz mode is a bit of a hybrid mode. It does auto-level, but also allows flips and rolls.</p> |

Betaflight Open-Source

The development of the Vortex would not have been possible without the effort of a large team of individuals who invested in the open source flight controller software that's running on the Vortex.

The variant of the open source flight controller firmware that we chose to power the Vortex is Betaflight, mainly due to it's solid support and active development.

Since the OSD firmware needs an intimate knowledge of the flight controller API, care must be taken when installing updated Betaflight builds (**IRCSYNERGYF3**).

The ImmersionRC team may not have support for beta, and recently released Betaflight builds the day they are released, but we are committed to keep up with changes.

Check the ImmersionRC Vortex product page for compatibility information.

NOTE: Do not install new Betaflight builds, nor builds of other Flight Controller software, without first verifying that they are supported by the Vortex OSD.

Betaflight Configurator Connection

To hook up the [Betaflight Configurator](#), hook up a Personal Computer via a standard Micro-USB cable, to the connector on the back of the Vortex.

Be aware that making certain changes via the configurator may break compatibility with the Vortex OSD. One example would be changing the channel order, which is set by the wizard.

Re-running the Vortex setup wizard will reset the Betaflight configuration to defaults.

NOTE: When Vortex will detect a new flight-controller version, it will automatically restart in TX Wizard mode.

Flight Controller Stick Commands

Enter Menu/Disarm Flight Controller:

Mode 2: Throttle stick left, and down (normal flight controller disarm control)
Mode 1: Yaw left, Throttle stick down

Arm Flight Controller:

Mode 2: Throttle stick right, and down
Mode 1: Yaw right, Throttle stick down

Reset vTx Channel:

Mode 2: Throttle Down, Rudder Left
+ Elevator Up, Aileron Left
Mode 1: Throttle Down, Rudder Left
+ Elevator Up, Aileron Left

ESCs - The 30A Vortex 230 Mojo ESC

Overview

The ESCs used in the Vortex 230 Mojo are a full-custom design, which uses a potent 32-bit ARM processor.

They are small enough to be enclosed completely in the plastic ESC covers of the Vortex 230 Mojo, where they are well protected against the elements, and from physical damage from passing tree-branches.

The ESCs come pre-configured for all motors supported by the Vortex, and they have also been used successfully with various aftermarket motors used by our test team.

NOTE: The ESCs used in the 230 Mojo support upgradable firmware, and can be updated to follow trends in protocols, etc. during the lifetime of your product.

RotorSENSE

A unique feature of the ESCs used in the Vortex is RotorSense.

This feature puts an end to the decade-old 'wire-swapping' technique used to get brushless motors to spin in the correct direction.

Once props are installed, at power-up before arming the flight controller, a simple spin of a prop will program the rotation sense.

NOTE: This procedure may be performed with props in place, or props removed. For safety's sake it is recommended that props are removed. If they are left installed, it is recommended to use a stick, or other object instead of a finger to flick the prop.

The full procedure is as follows:

- 1) Cycle power to the quad to ensure that the flight controller is not armed.
- 2) Spin the motor in the desired direction. If the ESC recognizes the spin, two short beeps will be generated.
- 3) Spin the motor again in the desired direction. If the ESC recognises the spin, 5 longer beeps will be generated and the ESC has learned the direction.

IMPORTANT: ImmersionRC ESCs DO NOT REQUIRE CALIBRATION. The calibration process required by most 'budget' ESCs is required since a precise quartz oscillator is not used in the ESC. The ImmersionRC ESCs all include this critical component, and therefore never need calibration.

Pro-Tuning

During the development of the Vortex, a team of pro-quad pilots spent countless hours, tweaking the tuning (PIDs) of the flight controller, using various 'PID Controllers' supported by the Cleanflight firmware

Each pilot fed back this data to the ImmersionRC team, and we incorporated it into the OSD firmware.

Now, as a user, you can choose your favourite pilot, choice of props, battery, flight style, etc. and all flight controller settings are configured for you, based upon his pro-tune.

Thanks to these pilots, you will spend less time in the field setting up the flight controller (quite an art), and more time racing.



R/C (Uplink) Receiver Selection

The Vortex 230 Mojo is shipped with three receiver interface cables, supporting 4 commonly used interfaces.

- a) 3-Pin 0.1" Servo Cable, for S-Bus, and CPPM (5V)
- b) 5-pin Picoblade for FrSky XSR receivers (5V)
- c) 3-pin JST-ZH for Spektrum DSMX receivers (3V)

Receivers may be mounted externally on the tail-end of the quad, or internally. Internally is definitely the preferred solution but does require a suitably small receiver.

The following are recommended for internal installation:

- 1) FrSky **XSR**, using the supplied XSR cable
- 2) FrSky **X4R-SB**, 'Naked' version with SBus output
Requires some soldering to wire sbus cable
- 3) Spektrum **SPM4648** Auto-bind receiver with supplied DSMX cable
Remove plastic case and heat-shrink for optimal fit
- 4) Spektrum **SPM9646** Carbon fuse receiver
- 5) Spektrum **SPM9649T** Telemetry receiver

To access the receiver bay for internal receiver mounting, remove the 12 screws which secure the top plate to the arms, and carefully remove the top plate.

The receiver connector is indicated by the 4-pin connector below. To mount the receiver, a small piece of double-sided tape may be used on the top of the metal can in the receiver bay.



Finally, the receiver antennas may be routed through the two notches in the bottom of the LED diffuser or the two notches in front of the rear arms in the side-plates, which is the preferred configuration. Make sure you apply some extra shrinkwrap to the fragile antenna wires to make sure they put up with some abuse from rough landings and crashes as well as handling the mini-quad.

Notes on Receiver Selection

One critical parameter to keep to a minimum in a race quad setup is latency. Latency from what the camera sees to the display device, and also from the control stick to the flight controller.

For minimum latency, with reasonable range, the Spektrum™ radios and satellite receivers are a great choice. If you desire a bit more range and more features the FrSky Taranis X9D or QX7 radio with a XSR receiver is an excellent choice.

Receiver Auto-Detection

A unique feature of the Vortex family of quadcopters is that the receiver type is auto-detected by the OSD when running the wizard.

R/C Transmitter Configuration

The advanced wizard used in the Vortex 230 Mojo is capable of detecting most transmitter configurations. Channel ordering, stick range, center position, etc. are all learned by the wizard.

In most cases it is better to start from a 'default' model on the R/C transmitter. On the Taranis, select the quadcopter option, and leave all settings as defaults.

Race Guidelines - Flying with Friends

The current generation of FPV Analog video link brings many advantages. Low-cost, and zero latency being two of the most significant. They do however suffer from less than ideal 'selectivity', even when using large channel spacing as is the case with RaceBand.

If a few simple rules are followed, quad racing can be a lot of fun.

- 1) **NEVER land near another pilot.**
This is an absolutely golden rule. Landing your quad near another pilot, especially one who is at a significant distance, is like screaming in the ear of someone listening to a whisper at the other side of a room.
- 2) **NEVER walk back to the pilot area with a powered-up quad**
This is similar to 1), and is the most common cause of issues at the race track. When retrieving a model, unplug the battery before walking back to the pilot area.
- 3) **POSITION the launch and landing zone as far from the pilot area as possible**
This ensures that collisions at race start don't affect other pilots. A distance of at least 10 meters is recommended, more than this is a bonus.
- 4) **ALWAYS warn in-air pilots before powering up a quad, even if you KNOW it is on a different channel**
Warn pilots, and be ready to power down IMMEDIATELY if a pilot is affected, and wait until he lands. Remember that it only takes a second or two, when flying race quads at speed, to crash and damage the quad, and whatever (or whoever) it hits.

Diagnostics - Motor Test

The Vortex 230 Mojo has a built-in diagnostic motor test. It can be useful to diagnose problems with ESC and/or Motors.

It's located in Vortex Menu>Diagnostics>Motor Test

WARNING: This test can be extremely dangerous, great care is required. The Vortex should be securely anchored to an immovable object, ideally one which doesn't block the airflow under the props. Holding the Vortex during the motor tests is highly in-advised!

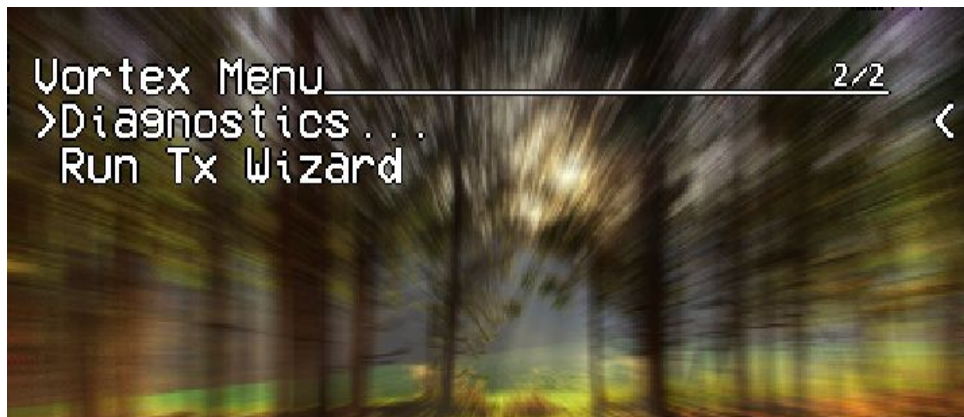

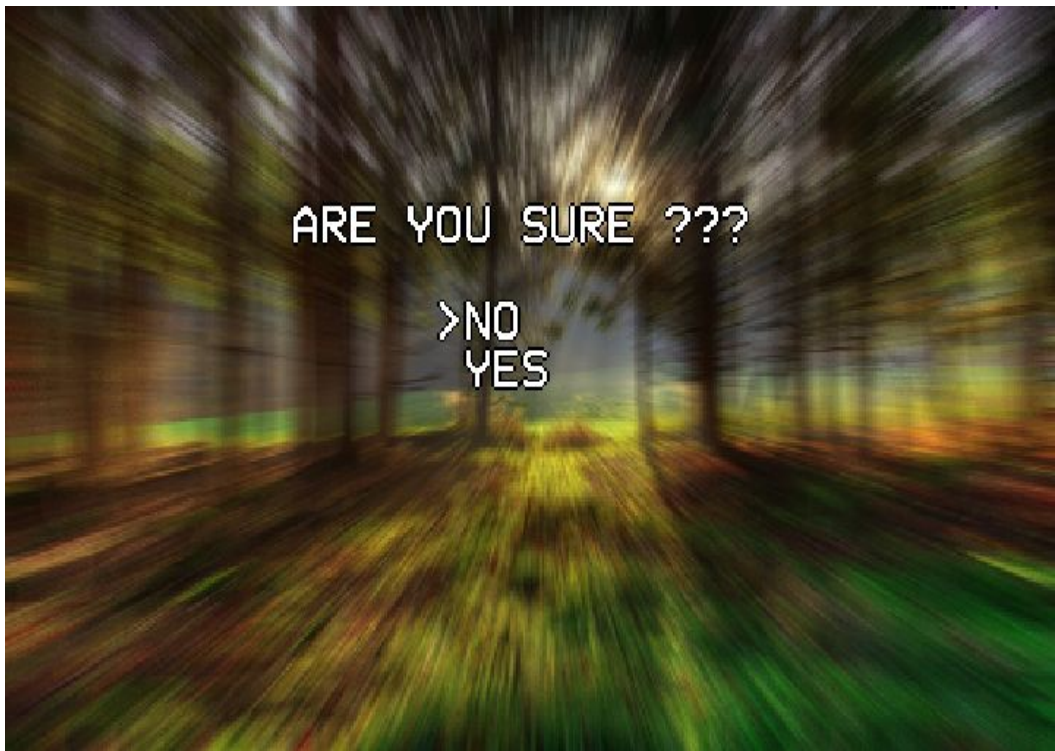
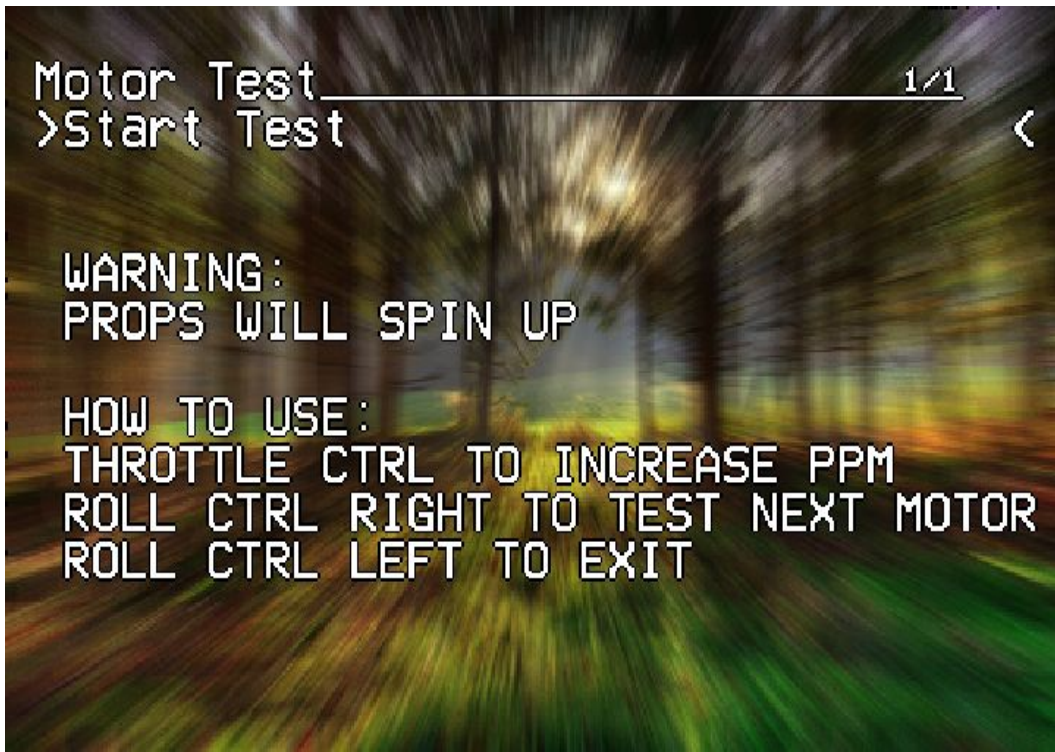

Motors will be tested independently in sequence, and then all together.

Use the roll stick left to go to next steps:

Motor1 -> Motor2 -> Motor3 -> Motor4 -> All Motors -> Test Summary



The summary screen and the graph could help you to identify a damaged motor:

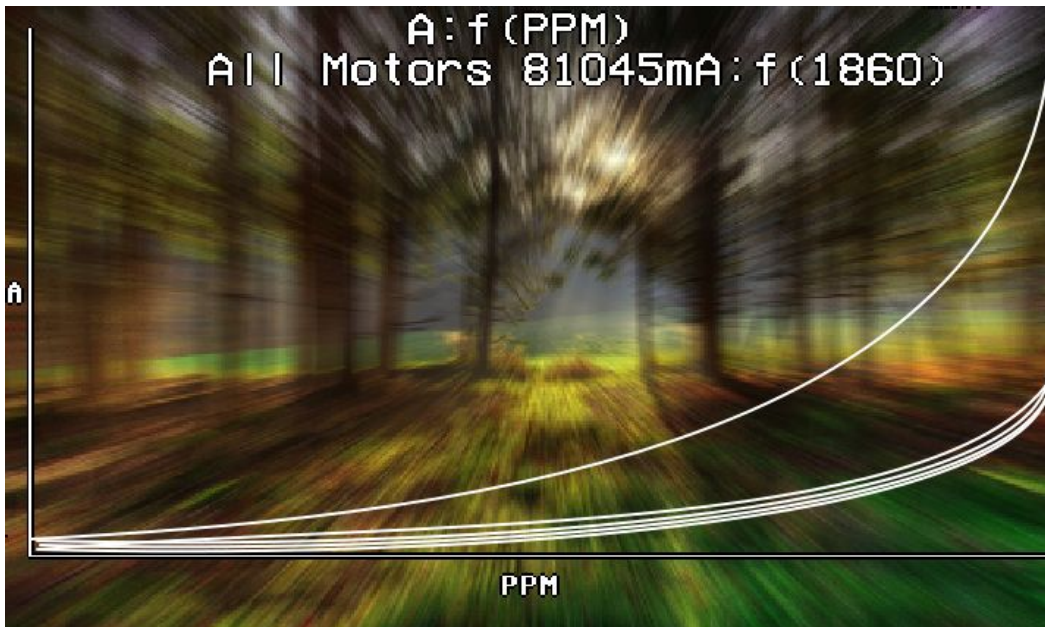

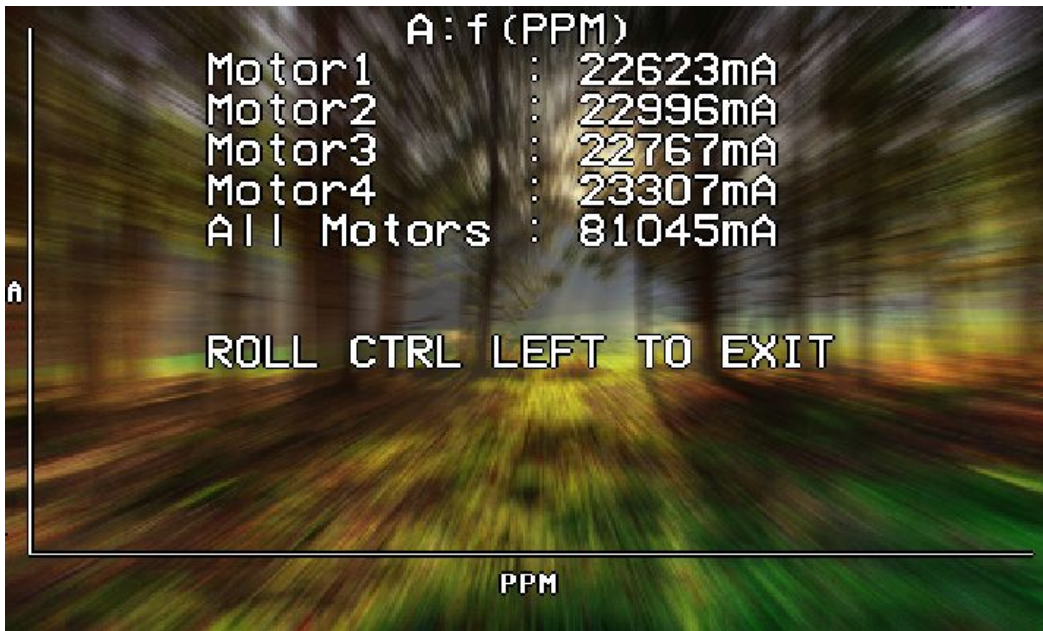

To exit the test move the Roll stick to the left.

Appendix A: Firmware Upgrades

Both the OSD, and the Flight Controller, are updated using the USB port on the rear of the Vortex.

Prior to any upgrade, please **remove all Props!**. If for any reason the props spin up during a firmware upgrade, serious damage to persons and/or property is very likely.

If your Vortex is not recognized as a valid USB device when you plug it in your PC, you will have to install a driver first. You can download it from here: [CP210x USB to UART Bridge VCP Driver](#)

To update the OSD and Flight Controller you will need to install two chrome applications:

1. [Vortex-configurator](#)
2. [Betaflight-configurator](#)

OSD Firmware Upgrades

To upgrade the OSD, use the Vortex-configurator Chrome app, do NOT use the old ImmersionRC Tools.

Please note that you need to rerun the Tx wizard after each up- or downgrade of the OSD firmware to make sure that the FC and OSD know the range and endpoints of your controls. Failure to do so might result in the OSD being unresponsive to the quad exhibiting strange behavior.

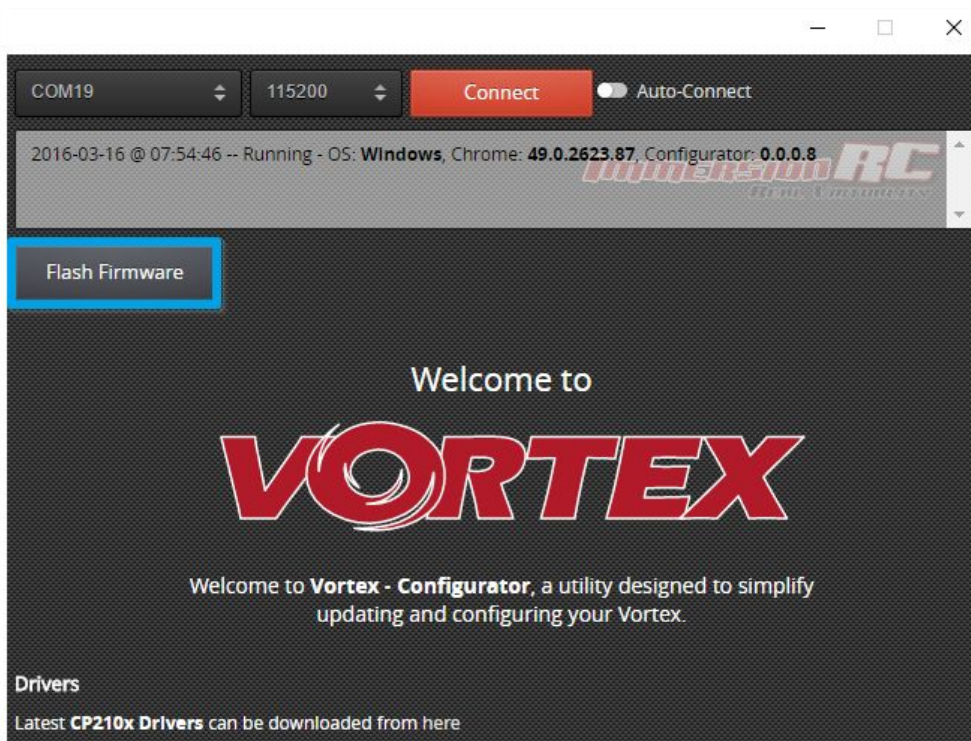

Upgrade procedure

- 1) Remove props, connect a Lipo.
- 2) Attach the Vortex to a Windows PC or a Mac using a standard Micro-USB cable (*ensure that this is a full USB cable, and not a power-only cable shipped with some products*)
- 3) Start Vortex-configurator from chrome://apps/
- 4) Make sure the right COM port is selected and press the **Flash Firmware** button.
- 5) Point to the update file (OSD_vX.X.X.fw) downloadable from the [Vortex 230 Mojo product page](#) on the ImmersionRC website, and start the update.

If during a previous upgrade you had a problem causing the OSD to be bricked, you can still recover from this state using the procedure below:

Upgrade procedure for bricked OSD

- 1) Press and hold the button on top of the Synergy flight controller (accessible through a hole in the front of the battery pad).
- 2) Remove props, plug in the Lipo (while still holding the fusion board button).
- 3) Release Synergy board button after 2 seconds.
- 4) Plug to USB
- 5) Start Vortex-configurator from chrome://apps/
- 6) Make sure the right COM port is selected and press the **Flash Firmware** button.
- 7) Point to the update file downloadable from the Vortex product page on the ImmersionRC website, and start the update.

Flight Controller Firmware Upgrades

To upgrade the Flight-Controller firmware, the same Vortex Configurator tool may be used.

Simply select the BetaFlight .hex file instead of the OSD .fw file when flashing. Use the betafight configurator to configure the flightcontroller after successful flashing.

NOTE: If flashing fails wait a few seconds and retry by clicking Flash Firmware. Sometimes it may need few attempts before it starts flashing, so keep trying. If after 5 retries it's still not working, retry the entire procedure.

Note that from time to time you may receive a 'STM32 - timed out, verification steps failed' message. As long as this states 'verify', and not 'program', you may safely ignore it (this was resolved in recent versions of firmware).

NOTE: Upgrading Betaflight to a version not supported by the OSD firmware can easily result in the OSD not functioning. Please refer to the Vortex product page on the ImmersionRC website for compatibility information.

NOTE: When Vortex will detect a new flight-controller version, it will automatically restart in TX Wizard mode. If not, force the TX Wizard using the Vortex app.

Appendix B: The Wizard - What else does it setup?

On startup the wizard will reset Betaflight configuration to its default state.

Once completed the following features, configurations and mode will be injected in Betaflight so you can start to enjoy your Vortex straight off the box with zero additional configuration needed:

| | |
|---------------------------|---|
| Flight Controller | |
| Failsafe | Enabled, Throttle set to 1100 |
| OneShot125 | Feature Enabled |
| Rx Mode | PPM Sum Mode (all channels down a single cable) |
| Minimum Throttle | 1100us |
| Maximum Throttle | 1900us |
| Minimum Command | 1015us |
| Angle mode on Aux1 | 1300 - 1700us |
| Horiz mode on Aux1 | 900 - 1300us |
| Acro mode on Aux1 | 1700 - 2100us |
| Channel Mapping | According to Wizard prompts |
| Accelerometer | Calibrated at wizard end |
| Pro-Tuning | Default ImmersionRC settings (based on Chad's tune) |

NOTE: If you have 'tweaked' any Betaflight settings outside of the Vortex OSD, please remember to back them up before running the wizard the next time, since it will reset them to default settings.

Appendix C: Video Tx - Staying Legal

Depending upon the Vortex variant purchased, and the Tx module installed, the video transmitter power output level, and available transmit frequencies can vary.

It is highly recommended to understand the rules and regulations in your country before using the Vortex. Transmitting outside a legal band is something frowned upon by the authorities, and may result in a fine, or confiscation of equipment.

As a rule of thumb, the following charts should help understand which frequencies are legal in each of our main markets.

ITU Region 2: Americas, Greenland, eastern Pacific Islands

Assuming that the user has a Ham license, the 5650 - 5925 MHz band may be used.

Note that all 8 channels of ImmersionRC's RaceBand are legal in in this region, with a Ham license.

| | 1 | 2 | 3 | 4 | 5 | 6 | 7 | 8 | |
|---|------|------|------|------|------|------|------|------|----------|
| 1 | 5740 | 5760 | 5780 | 5800 | 5820 | 5840 | 5860 | 5880 | IRC/FS |
| 2 | 5658 | 5695 | 5732 | 5769 | 5806 | 5843 | 5880 | 5917 | RaceBand |
| 3 | 5705 | 5685 | 5665 | 5645 | 5885 | 5905 | 5925 | 5945 | Band E |
| 4 | 5733 | 5752 | 5771 | 5790 | 5809 | 5828 | 5847 | 5866 | Band B |
| 5 | 5865 | 5845 | 5825 | 5805 | 5785 | 5765 | 5745 | 5725 | Band A |

With the FCC power limit for analog transmissions being so low for license-free use, it is not very interesting for race quad use. At present, ImmersionRC does not ship a ~1mW version of the Vortex transmitter module. This may change in the future.

ITU Region 1: Europe, Africa, Middle East, Iraq, Soviet Union

Without a license, only the 25mW Tx module may be used, and then only in the ISM band from 5725 MHz thru 5875 MHz.

| | 1 | 2 | 3 | 4 | 5 | 6 | 7 | 8 | |
|---|------|------|------|------|------|------|------|------|----------|
| 1 | 5740 | 5760 | 5780 | 5800 | 5820 | 5840 | 5860 | 5880 | IRC/FS |
| 2 | 5658 | 5695 | 5732 | 5769 | 5806 | 5843 | 5880 | 5917 | RaceBand |
| 3 | 5705 | 5685 | 5665 | 5645 | 5885 | 5905 | 5925 | 5945 | Band E |
| 4 | 5733 | 5752 | 5771 | 5790 | 5809 | 5828 | 5847 | 5866 | Band B |
| 5 | 5865 | 5845 | 5825 | 5805 | 5785 | 5765 | 5745 | 5725 | Band A |

ITU Region 1: Europe, Africa, Middle East, Iraq, Soviet Union

With a Ham license, the legal band varies widely from country to country, but taking France as an example, Ham users may use the band 5650 through 5850 MHz with more than 25mW.

| | 1 | 2 | 3 | 4 | 5 | 6 | 7 | 8 | |
|---|------|------|------|------|------|------|------|------|----------|
| 1 | 5740 | 5760 | 5780 | 5800 | 5820 | 5840 | 5860 | 5880 | IRC/FS |
| 2 | 5658 | 5695 | 5732 | 5769 | 5806 | 5843 | 5880 | 5917 | RaceBand |
| 3 | 5705 | 5685 | 5665 | 5645 | 5885 | 5905 | 5925 | 5945 | Band E |
| 4 | 5733 | 5752 | 5771 | 5790 | 5809 | 5828 | 5847 | 5866 | Band B |
| 5 | 5865 | 5845 | 5825 | 5805 | 5785 | 5765 | 5745 | 5725 | Band A |

Appendix D: LED Board - Status report

The RGB LEDs on the rear of the Vortex 150/180/230 are used by the OSD during the startup phase to report flight controller sensor status, FC API compatibility, and video link status information.

From left to right the bottom led board will turn green (or red if a problem is detected) one after another as follows:

1. GYRO sensor detected
2. ACCEL sensor detected
3. Flight Controller/OSD APIs Compatible
4. Camera detected

At the end of the initialization sequence, the led board will blink in green if all tests passed, or it will blink in red if any test failed.

It will also blink in green for 3 seconds when you arm your Vortex.

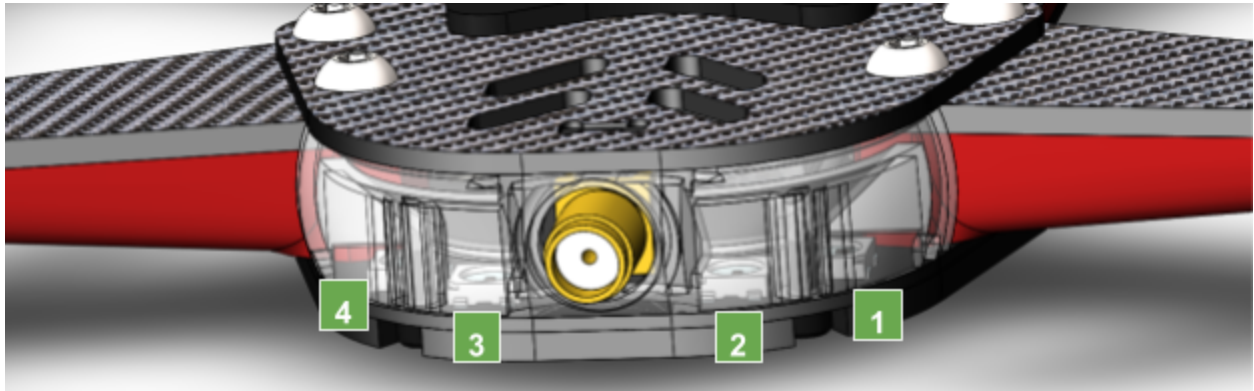

Looking after your Vortex

Snow and Water

Even though most of the PCBs in the Vortex are coated with a [conformal coating](#), which does offer some protection from water, it **is not recommended** to get the Vortex wet, even if that water comes in the form of snow.

If your Vortex does get wet, immediately remove power, and place it in a sealed container containing uncooked rice, for 24 hours. The rice will absorb some of the water.

If the Vortex falls into salt water, damage may be more serious, and requires rinsing the quad with a bath of [distilled water](#) before placing it in the sealed rice container. The Tx module may not survive this ordeal, and may require replacing.

Note that even if the Vortex survives a salt-water bath, long term corrosive effects of the salt on any exposed copper surfaces may result in the product failing at some point in the future.

The Sun

The camera use in the Vortex (or any camera for that matter) does not appreciate being left staring at the sun for long periods of time.

LiPos also have a habit of living short lives when exposed to extreme heat.

It is highly recommended to store the Vortex in the shade between flights.

Dirt

The typical mini-quad tends to live a life coated in a thick layer of grass, dirt, and other materials which happen to be in the way during landings, whether intentional, or otherwise.

It is highly recommended to keep the Vortex clean of foreign materials, especially those which tend to conduct electricity when wet.

A toothbrush is the best tool to keep your Vortex 150 Mini looking like new. Stiff bristles are great at working dirt from hard-to-clean locations.

Jealous Friends

The Vortex does appear to have a kind of magnetic personality which could result in your Vortex ending up in the bottom of your best mates packback.

This is probably the most serious of the issues listed above, take care and good luck!

Specifications

| | |
|-----------------------------|---|
| Flight Controller | |
| IMU | Invensense SPI Gyro/Accelerometer, 8kHz loop speeds |
| CPU | STM32F303 32-bit ARM processor |
| Firmware | Betaflight compatible (<i>with API version matching that of the OSD</i>) |
| | |
| OSD | |
| CPU | STM32F373 32-bit ARM processor |
| Resolution | 440H x 280V |
| Style | White, with black surround around all pixels |
| Output | Programmable Black/White levels |
| | |
| Video Tx Features | |
| Transmitter Module | Custom, integrated into the FC/OSD board |
| Channels | 40 Initially, programmed via OSD |
| Bands | 5, including the ImmersionRC/FatShark bands, and RaceBand |
| Frequency, IRC/FS | 5740, 5760, 5780, 5800, 5820, 5840, 5860, 5880 MHz |
| Frequency, RaceBand, CH1..8 | 5658, 5695, 5732, 5769, 5806, 5843, 5880, 5917 MHz |
| Frequency, 'A' Band, CH1..8 | 5865, 5845, 5825, 5805, 5785, 5765, 5745, 5725 MHz |
| Frequency, 'B' Band, CH1..8 | 5733, 5752, 5771, 5790, 5809, 5828, 5847, 5866 MHz |
| Frequency, 'E' Band, CH1..8 | 5705, 5685, 5665, 5645, 5885, 5905, 5925, 5945 MHz |
| Power Output | 1mW -> 600mW +/- 1dB, with regional locked SKUs * |
| Audio | Stereo, Right channel used for Telemetry, Left channel routed to onboard mic. |
| Microphone | Onboard (Left Channel) |
| Recommended Antenna | Supplied SpiroNET v2 Omni, Skew Planar, 4 leaf |
| Glitch-free Channel Change | Supported |
| TNR Channel Change | Integrated (requires NFC Wand v1.1 or later) |
| | <i>* Dynamic power control always on, 25mW Max. before takeoff</i> |
| | |
| Power Train | |
| Standard Prop | HQ 5x4.3x3 V1S Black |
| Maximum Prop Size | 5" |
| Stock Motors | BrotherHobby Returner R3 2206 2300kV |
| Recommended Battery | 1300-1500mAh 4S >65C |
| | |
| | |

| | |
|-------------------------------|--|
| ESC | |
| Type | ImmersionRC EzESC |
| Rating | 30A continuous, 40A peak |
| Features | Dshot600, Multishot, OneShot125, OneShot42, MultiShot, rotorSENSE, Motor Braking |
| Processor | 32-bit ARM |
| | |
| R/C Receiver | |
| Channels Required | Absolute minimum four. Five recommended to support mode switch. |
| Interface Standard | CPPM, S-Bus, Spektrum, XBus, SumH, SumD (auto-sense with manual override) |
| Receiver Power | +5V, or +3.3V @ 200mA max. |
| | |
| Flight Characteristics | |
| Flight Time | Depends upon battery, and flight style |
| Maximum Range | Highly dependent on battery, and flying style |
| Maximum Speed | > 100km/h with appropriate props and battery |
| | |
| Camera Support | |
| Video Standard | Composite, PAL or NTSC, switchable using a camera-mounted jumper |
| | |
| Weight and Size | |
| Weight | Approx. 350grams without battery |
| Size | 230mm between diagonal motors |

Spare parts and Upgrades

Several crash kits, and upgrades, are available for the Vortex 150/180 Mini, including the following:

| Part Numbers | |
|--------------|--|
| V23ESC30 | Replacement ESC, 30A |
| V23PDB | Replacement PDB - Vortex 230 Mojo |
| V15MSYN | Replacement Synergy (which includes the vTx) |
| V23CK2 | Crash Kit 2, top plate + battery pad |
| V23CK3 | Crash Kit 3, arm assembly + plastic cover |
| V23CK4 | Vortex 230 Mojo front section - camera holder etc. |
| V23CAB | Flat-flex, camera, receiver, U.FL->SMA cables |
| V23220623 | Spare motor, 2206 2300kV |
| V23CK1WT | Vortex 230 Mojo pimp kit - white |
| V23CK1BK | Vortex 230 Mojo pimp kit - black |
| V23CK1BL | Vortex 230 Mojo pimp kit - blue |
| V23CK1RD | Vortex 230 Mojo pimp kit - red |
| V23CK1OR | Vortex 230 Mojo pimp kit - orange |
| V23CK1YL | Vortex 230 Mojo pimp kit - yellow |
| V23CK1GN | Vortex 230 Mojo pimp kit - green |
| V23CK5 | Vortex 230 Mojo - all screws and standoffs |

Please contact your reseller for ordering any spare parts required.

Support

First line of support is handled by the reseller. If you encounter any problems with your ImmersionRC product please contact them first.

For support on issues involving equipment from other brands and also general support for ImmersionRC products, the best place to go is the ImmersionRC section of FPVlab.com.

We actively monitor this forum and provide support here.

A very active Facebook Group is also a good place to go with support, or any other pre/post sales inquiries for the Vortex product line:

<https://www.facebook.com/groups/ImmersionrcVortex>

As a last resort, ImmersionRC runs a global network of repair and support centers. These handle warranty repairs, supply hard-to-find spare parts, and also handle non-warranty work.

Send an email to repairs@immersionrc.com to open a support ticket.

Frequently Asked Questions

Q. How do I calibrate my ESCs?

DO NOT CALIBRATE THEM! ImmersionRC ESCs use quality components with accurate timing and never require calibration!

Q. Can I fly in the rain?

ImmersionRC is one of the only companies in the racing quad business which conformally coats key PCBs to add a level of water-resistance. This avoids problems when flying in very humid areas, occasional crashes in wet grass, and the occasional use of the front of the quad as a snow-shovel.

That said, not all components like getting soaked, the R/C Rx for example, or the sensitive video transmitter module. For this reason, flying in the rain (which isn't much fun anyway) is not really recommended.

Q. I dunked my Vortex in the ocean/lake/pond, what do I do?

First thing to do (especially where highly corrosive salt water is involved) is to rinse the entire quad in distilled water (available where car parts are sold, used to refill car batteries).

This rinsing process will remove potentially conductive salts from the water, and will ensure that they don't remain after drying.

Once the quad is rinsed, place it in a zip-lock bag filled with rice, and leave it in a warm place for at least 48 hours. The rice will absorb the remaining water, and increase the chances of life for your quad after the dunk.

Q. My motors are 'stuttering', and the quad falls out of the sky under full throttle

This is almost always due to motor screws touching the windings. Motor screw length on any mini-quad is absolutely critical, especially for 'upgrade' motors which have extremely thin base material.

Q. My R/C Receiver isn't auto-detected by the wizard

Normally, the Vortex will start up in a receiver 'auto-detect' mode which will automatically identify the connected PPM/SBUS/DSMX. Receiver.

From time to time (for reasons not yet understood) this process fails. To work around this, simply connect the quad to a PC/Mac and using the Vortex Configurator manually set the receiver type.

Q. I don't like the stock camera, and would like to upgrade it

With previous Vortex quads, which shipped with a CMOS camera, there were clear reasons to do this. For the Vortex 230 Mojo, we have installed a top-of-the-line CCD camera, with integrated OSD control, and a wide GoPro lens, why would you want to upgrade that?

Q. My Vortex is playing Crazy Train song

The tunes is emitted by ESC when overvoltage is detected (> 17.4 V). For the 30A ESCs, the maximum voltage tolerated is that supplied by 4s HV LiPo packs.

Note that if the ESC gets wet, it can cause it to believe that an overvoltage condition exists.

Q. My Vortex emits 2 long beeps followed by a short beep on startup (---)

This sequence is played on startup when the vortex was not able to detect a camera. In that case you should check the camera is correctly plugged on both side.

Q. When I fly, all I see is the ground

Tilt the flight camera up! (but beware that landing with a heavily tilted flight camera can be more of a challenge).

A useful trick when setting camera angle is to take note of the position of your head while flying. If you find yourself constantly looking up, angle the camera up. If you find yourself constantly looking down, angle the camera down.

Q. My Vortex flips instead of taking off

Check that the correct props (CW vs. CCW) are installed in the correct locations. Also check that the props rotate in the correct direction, and run [RotorSENSE](#) on each motor that needs reversing.

Q. I updated to the latest BetaFlight x.y.z and my quad is no longer tuned

BetaFlight is a superb piece of software, updated almost daily to add new features, and is really the 'bleeding edge' of flight controller code. Unfortunately, this also means that 'stability', or 'backwards compatibility' is not a priority.

The Pro-Tunes shipped with the Vortex 230 Mojo were painstakingly tuned using the version of Betaflight that we shipped with. We cannot guarantee that all future versions of either of these firmware bases will keep this same fine level of tune.

From time to time we will commit to providing updates which synchronize the OSD, Flight Controller, and the Pro-Tunes. Check the ImmersionRC website, Vortex 230 Mojo page occasionally for news on these updates. .



Regulatory notice

The use of this product may be prohibited in your country/region/state, please verify that the RF output power and frequencies used by this transmitter comply with local rules and regulations, this product may require a license to operate.

Directions on safety

ImmersionRC advocates the safe use of their products, always make sure you equipment is in proper working order, is checked prior to every flight and that your are familiar with and respect the equipment's capabilities and limitations. Do NOT fly recklessly, do NOT fly near airports, freeways, towns, people, etc, basically anywhere where a equipment failure or pilot error can result in injury or damage to people and/or property.

Warranty

For warranty claims or repair requests please consult the retailer that you purchased this product from, they will be able to help you with your warranty claim or repair request.

Social Networks

Like Us

We would like thank you for purchasing this ImmersionRC product.

Like ImmersionRC's Facebook page and be kept up-to-date with news, product releases, firmware updates, tips and tricks, and other information relevant to the FPV hobbyist.

<http://www.facebook.com/ImmersionRC>



You can also follow us on Google Plus

google.com/+immersionrc



We have even been known to Tweet on occasion

<https://twitter.com/@immersionrc>

Index

[Thank You!](#)

[Getting Started for Newcomers to Race Drones](#)

[Getting Started, ARF Version](#)

[The Anatomy of a Vortex 150/180 Mini](#)

[Connectors and Switches](#)

[Connector Part Numbers and Sources](#)

[Arm Assembly](#)

[Camera Mounting](#)

[Flight Camera](#)

[Lost Model Alarm](#)

[The Touch'n'Race \(TNR\) Tag](#)

[The On Screen Display \(OSD\)](#)

[The Welcome Screen](#)

[The Main Menu](#)

[The LED Setup Menu](#)

[The Flight Controller Menus](#)

[The Video Tx Menu](#)

[The Camera Settings](#)

[Video Transmitter](#)

[OSD Menu](#)

[TNR Wand](#)

[PitStick Mode](#)

[Flight Controller](#)

[R/C Transmitter Control Modes](#)

[Flight Modes](#)

[Betaflight Open-Source](#)

[Betaflight Configurator Connection](#)

[Flight Controller Stick Commands](#)

[Overview](#)

[RotorSENSE](#)

[Pro-Tuning](#)

[R/C \(Uplink\) Receiver Selection](#)

[Notes on Receiver Selection](#)

[Receiver Auto-Detection](#)

[Race Guidelines - Flying with Friends](#)

[Diagnostics - Motor Test](#)

[Hardware Upgrades](#)

[Appendix A: Firmware Upgrades](#)

[OSD Firmware Upgrades](#)

[Upgrade procedure](#)

[Upgrade procedure for bricked OSD](#)

[Flight Controller Firmware Upgrades](#)

[Appendix B: The Wizard - What else does it setup?](#)

[Appendix C: Video Tx - Staying Legal](#)

[ITU Region 2: Americas, Greenland, eastern Pacific Islands](#)

[ITU Region 1: Europe, Africa, Middle East, Iraq, Soviet Union](#)

[ITU Region 1: Europe, Africa, Middle East, Iraq, Soviet Union](#)

[Appendix D: LED Board - Status report](#)

[Looking after your Vortex](#)

[Snow and Water](#)

[The Sun](#)

[Dirt](#)

[Jealous Friends](#)

[Specifications](#)

[Spare parts and Upgrades](#)

[Support](#)

[Frequently Asked Questions](#)

[Q. How do I calibrate my 150/180 Mini ESCs?](#)

[Q. Can I fly in the rain?](#)

[Q. I dunked my 150/180 Mini in the ocean/lake/pond, what do I do?](#)

[Q. My motors are 'stuttering', and the quad falls out of the sky under full throttle](#)

[Q. My R/C Receiver isn't auto-detected by the wizard](#)

[Q. I don't like the stock camera, and would like to upgrade it](#)

[Q. My Vortex is playing Crazy Train song](#)

[Q. My vortex emits 2 long beeps followed by a short beep on startup \(--\)](#)

[Q. When I fly, all I see is the ground](#)

[Q. My Vortex Mini flips instead of taking off](#)

[Q. I updated to the latest BetaFlight x.y.z and my quad is no longer tuned](#)

[Regulatory notice](#)

[USA Drone Registration](#)

[Directions on safety](#)

[Warranty](#)

[Social Networks](#)

[Like Us](#)

[Index](#)